

Aivon Oy

Manual

BoBoX 3 (2018)

BreakOutBoX with grounding

AIVON OY

BoBoX 3



© Aivon Oy
Valimotie 13A
00380 Helsinki, Finland
www.aivon.fi

Table of Contents

Main features	2
Basic schematic	3
Output connection	4
Installation of filter components	5
Specifications	7
Document revision history	7

BoBoX 3 (2018)

BreakOutBoX with grounding

A ivon BoBoX 3 (2018) is a improved version of BoBoX 3 that is a versatile breakout box for separating and filtering signals from a multipin Fischer connector to BNC connectors. The main improvement to old BoBoX 3 models is wider pcb gaps that provide larger peak voltages in the lines. Each line can be separately grounded and optional filtering can be added inside the unit.



Main features

- User selectable grounding for each line. Either:
 - Fischer-end of the line is connected to BNC *or*
 - Fischer-end of the line is connected to printed circuit board common ground.
 - by default the grounded line is not simultaneously connected to BNC
 - optionally, BNC can be permanently connected to line regardless of state of grounding
 - pcb common ground is internally connected to chassis using wire.
 - Optionally a *third* position can be taken into use for custom purposes e.g. connecting the line to auxiliary connector
- Shields of uninsulated BNC connectors are permanently connected to chassis
- On-board RC-filter pads for user-defined components
 - by default no filtering i.e. $R = 0$ Ohms, $C = \text{open}$.
 - R and C surface-mount size 0603
- Output connector Fischer DGP 105 A093 or a custom one.
 - mates with S 105 A093, output cable available
 - shield of output connector is connected to chassis. Optionally shield can be floated using isolating adapter piece
- 19" rack mountable.

Note: this is a low-frequency RC-filtering unit. User should filter out higher frequencies for example with ferrite beads in the output cable if low noise operation is required.

Basic schematic

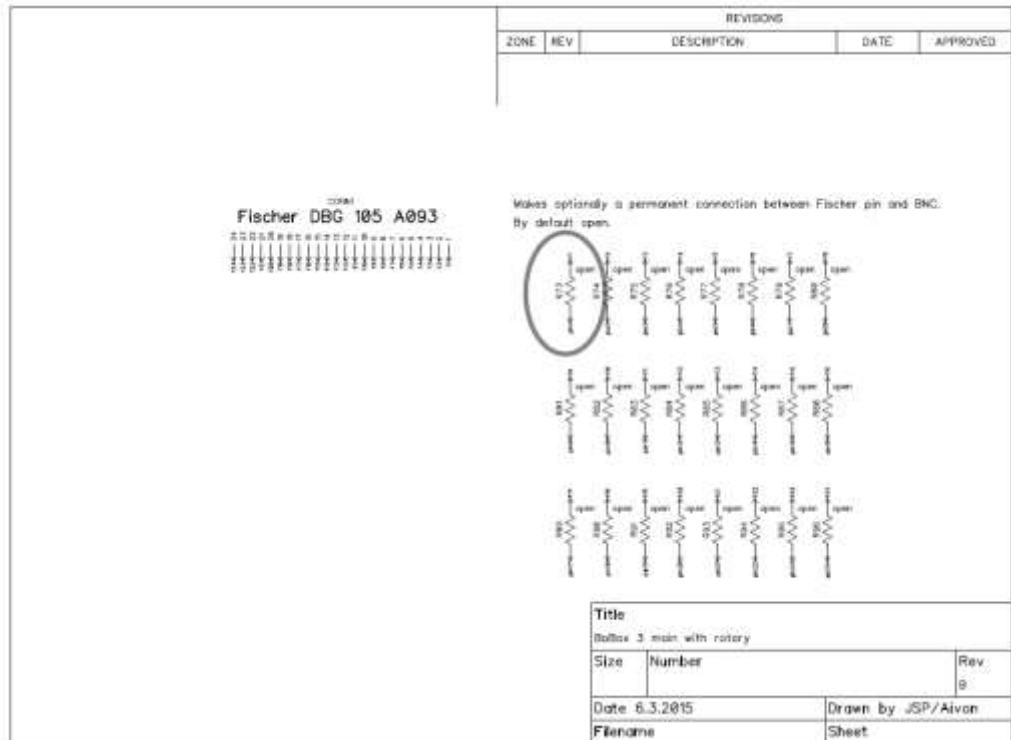
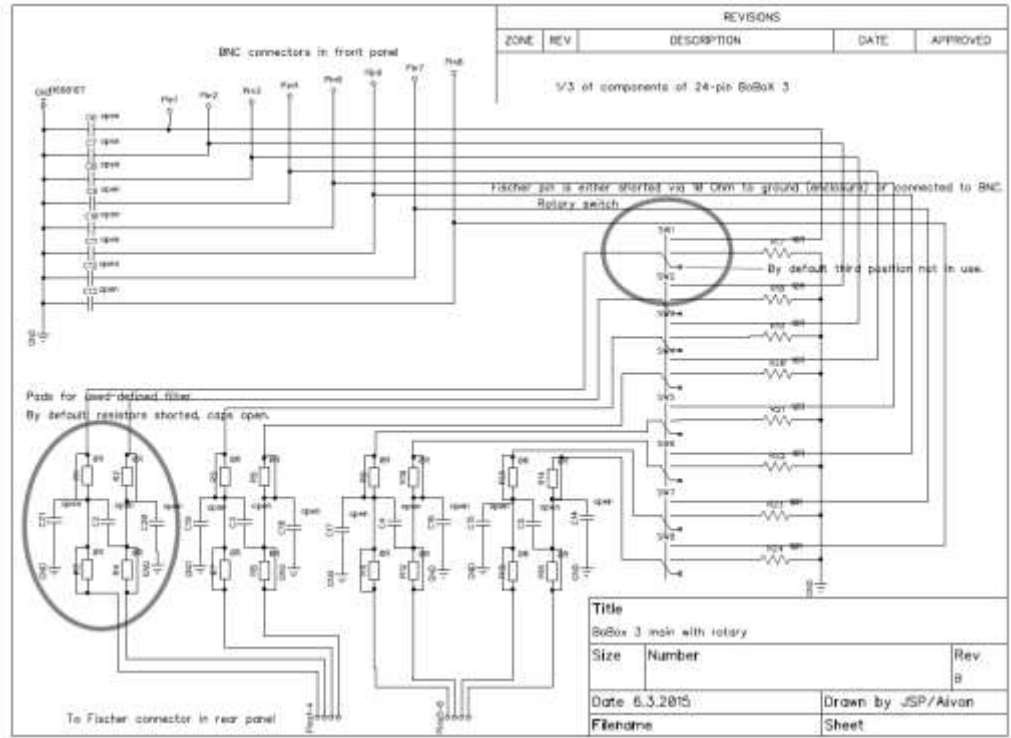

Output connection

In rear panel of BoBoX 3 there are engravings to mark pin numbering and a Fischer DGP 105 A093 connector for signals out.



Installation of filter components

- 1) Remove all M3 screws from panels and the decorated nut



- 2) Open rear panel and undo the grounding cord from the rear panel

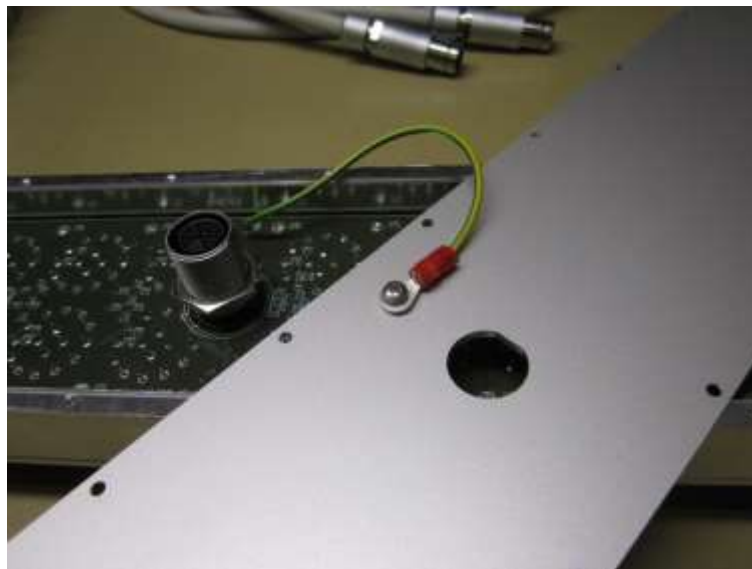

- 3) You can also remove the metallic frame by removing all its screws from the front panel size. This is not necessary for soldering the filter components.

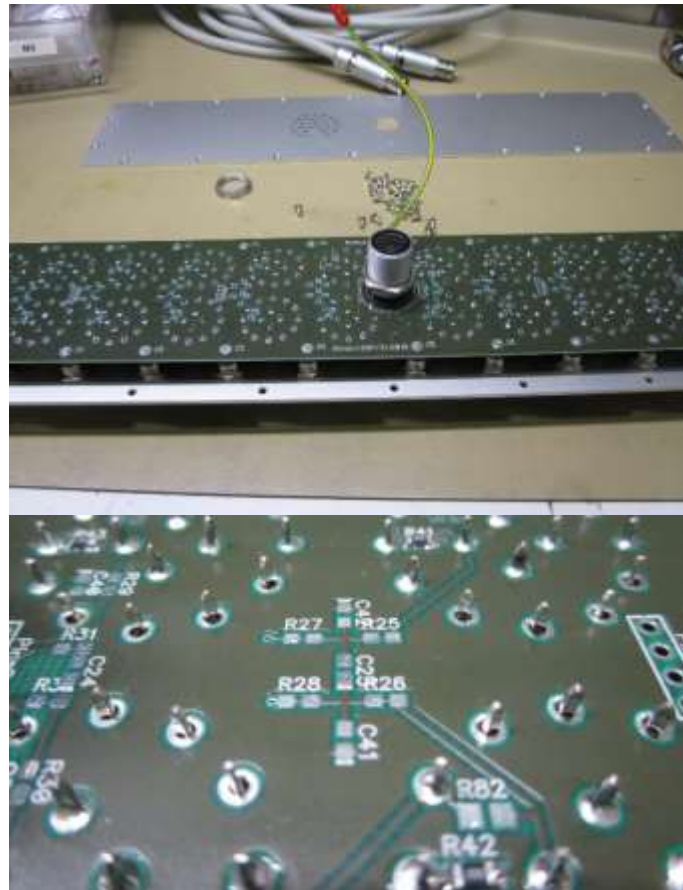

- 4) Locate the pads for filter components. See separate schematic for components names. Resistor sites are shorted between its pads on pcb and the user has to **cut the short** using a sharp blade **prior to soldering** a desired resistor. Use size 0603 SMD components.

Specifications

Absolute maximum ratings

Voltage	± 100 V (NEW in Oct 2018!!!)
----------------	------------------------------

Connectors

Input	BNC
Output	Fischer DGP 105 A093 or custom

Enclosure

Material	Anodized aluminum
-----------------	-------------------

Physical dimensions

Enclosure dimensions (Width x height x depth)	483 mm x 90 mm x 65 mm
Weight	1.55 kg

Document revision history

Date	Version	Description	Author
8.5.2015	0.1	Initial draft	JSP
27.9.2018	1.0	Better schematics	JSP
18.10.2018	1.1	Improved BoBoX 3 (2018)	JSP